

SD1b-G

85W

FEATURES

- Die cast aluminium housing
- Powder coated for corrosion resistance
- High temperature resistant tempered glass lens
- Anodised aluminium reflector

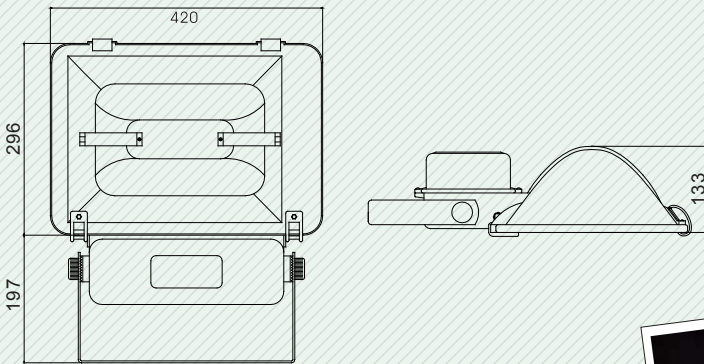

SUPPORTED LAMPS

- 85 watt



APPLICATIONS

Floodlighting, warehouses, airports, service stations, billboards etc...



Luminaire No	Lamp No	Wattage (W)	Psu Frequency (Hz)	Input Voltage (V)	Input Current (A)	Ingress Protection
SD1b-G-85W	SD85W-F-G	85W	50/60	240	0.40	IP65(ballast case)

"Creating Energy Saving Solutions for a Sustainable Future"