

SD2b-G

85W•125W•155W

FEATURES

- Recessed indoor luminaire
- Powder coated sheet metal construction
- Mesh diffuser

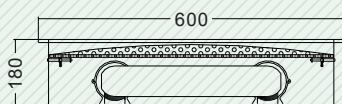
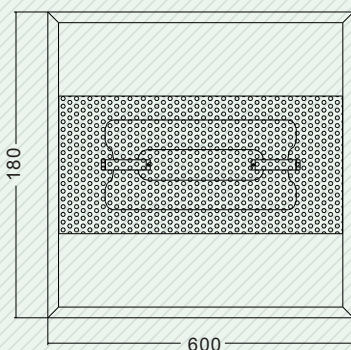

SUPPORTED LAMPS

- 85 watt
- 125 watt
- 155 watt



APPLICATIONS

Offices, hotels, retail stores, restaurants, warehouses, hallways etc...



Luminaire No	Lamp No	Wattage (W)	Psu Frequency (Hz)	Input Voltage (V)	Input Current (A)
SD2b-G-85W	SD85W-F-G	85W	50/60	240	0.40
SD2b-G-125W	SD125W-F-G	125W	50/60	240	0.57
SD2b-G-155W	SD155W-F-G	155W	50/60	240	0.65

"Creating Energy Saving Solutions for a Sustainable Future"