

SD-H-SD4

85W•125W•155W

FEATURES

- Die cast aluminium housing
- Powder coated for corrosion resistance
- High temperature resistant tempered glass lens

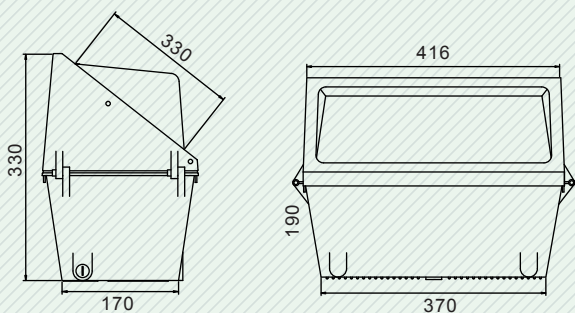

SUPPORTED LAMPS

- 85 watt
- 125 watt
- 155 watt



APPLICATIONS

Wall pack, warehouses, factories, tunnels etc...

Luminaire No	Lamp No	Wattage (W)	Psu Frequency (Hz)	Input Voltage (V)	Input Current (A)	Ingress Protection
SD-H-SD4-85W	SD85W-F-G	85W	50/60	240	0.40	IP43(ballast case)
SD-H-SD4-125W	SD125W-F-G	125W	50/60	240	0.57	IP43(ballast case)
SD-H-SD4-155W	SD155W-F-G	155W	50/60	240	0.65	IP43(ballast case)

"Creating Energy Saving Solutions for a Sustainable Future"